

# 30-2056B

## Infrared Flame Detector



Conventional Initiating Devices

### General

The **Pyrotector Model 30-2056B IR Flame Detector** is a compact, unitized package containing an IR detection cell, solid state electronics and dry Form-C (SPDT) contacts for alarm and fault conditions. The detector is engineered to respond to the nominal 4.45 micron band of infrared radiation, which is commonly known as the CO<sub>2</sub> spike. See **Figure 1**. A characteristic of burning hydrocarbons is the emission of unusually high levels of IR radiation in this narrow portion of the radiation spectrum. On the other hand, extraneous light sources that are capable of triggering an alarm in other types of fire detectors emit very low levels of radiation in this range. By concentrating on this narrow band of the spectral range that is highly specific to burning hydrocarbons, combined with the use of optical filters to discriminate against most extraneous background radiation from a variety of sources, including hot objects, the Model 30-2056B is able to provide a high level of reliable fire detection, while being relatively immune to false alarm signals.

The detector is compatible with most 24-volt filtered DC four-wire fire alarm control panels.

### Features

- High immunity to false alarms caused by lightning, arc welding, x-rays and sunlight.
- Compatible with standard alarm systems.
- Remote test feature assures reliable response.
- Explosion-proof and watertight housing for use in a variety of applications.

### Application

The Pyrotector Model 30-2056B Infrared Flame Detector is designed for use in applications where the occurrence of lightning or arc welding within the protected area can cause an ultraviolet fire detector to register a false alarm. The detector is virtually immune to actuation caused by lightning, arc welding, and most other extraneous light sources. It is ideally suited for use in a variety of both indoor and outdoor applications, in nearly any ambient lighting environment, including the full range of artificial lighting. The housing is explosion-proof, watertight, and dust-tight, and conforms to applicable NEMA and NEC requirements. Typical applications that can use the 30-2056B flame detector include:

- Hydrocarbon processing plants.
- Hazardous storage facilities.
- Offshore oil platforms.
- Airport facilities.
- Fuel loading racks.

### DETECTOR RESPONSE TIME

The response time of the detector depends on the size of the fire, the rate of propagation, fire type, and the proximity of the fire to the detector. The average response time to a one square foot gasoline fire at 50 feet is less than 6 seconds.

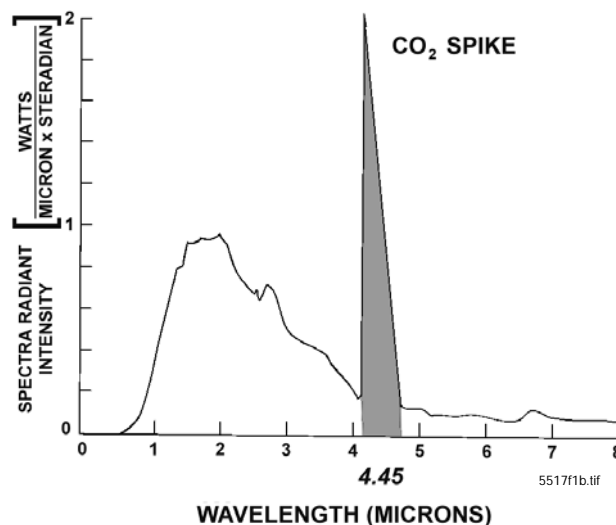

**Figure 1**  
**Spectral Sensitivity Range for Hydrocarbon Fires**

## REMOTE TESTING

The detector has a remote test feature that allows the operator to test the detection circuitry for proper function and also check the optical integrity of the lens from a location that is remote from the detector installation. To initiate a test, the operator places the system in bypass and simply presses a test switch, usually located at the control panel. This actuates an integral IR radiation source that is mounted inside the detector, resulting in the simulation of a flickering fire. Upon detection of the simulated fire, the detector latches into an alarm condition to indicate that it is operating correctly. The detector can then be reset by interrupting power to the unit for a minimum of 0.3 second. The detector will fail remote testing if 50% of the detection range is lost.

The LED is illuminated during an alarm condition to serve as an integral visual alarm indicator.

**IMPORTANT: Proof of successful remote test is activation of alarm relay.**

## Cone of Vision

The detector has a nominal 80 degree cone of vision. However, the detector can be rotated up to 360° so that the area to be protected is within its cone of vision. Proper aiming and adequate coverage is recommended to ensure hazardous area protection. See **Figure 2** below.

## Theory of Operation

The electromagnetic emission of a hydrocarbon fire is characterized by a strong band in the 4.2 to 4.7 micron range. This band, known as the CO<sub>2</sub> spike, is caused by the emission of energy generated by excited CO<sub>2</sub> molecules. Since this is the dominant feature of the spectral emission for hydrocarbon fires, the IR sensor is designed to respond with peak sensitivity to radiant energy at the 4.45 micron range.

The detection cell is a specially developed pyro-electric cell with an integral optical filter window, which restricts incoming

light to the wavelength band 4.2 to 4.7 microns (the CO<sub>2</sub> spike). The detection cell responds by generating a signal that is proportional to the radiation being detected.

The electronic circuitry that processes the signal from the detection cell checks for flicker response, ignoring signals from spurious light sources. The flicker rate and count requirements are factory set for levels characteristic of a hydrocarbon fire. A flickering signal that exceeds the preset alarm threshold will result in actuation of the alarm relay.

## Specifications

**Operating voltage:** 18 to 32 VDC, with maximum ripple 0.5 vpp at 60 to 120 Hz.

**Operating current:** *Standby:* 1 watt. *Alarm:* 3.5 watts maximum.

**Relay contact rating:** Alarm and Fault Relays have Form-C contacts and are rated for 2.0 at 30 VDC.

**Spectral sensitivity range:** 4.2 to 4.7 microns.

**Response time:** Detector responds to a 1 foot-square gasoline fire (at zero axis to detector) in less than 6 seconds at 50 feet.

**Cone of vision:** 80 degrees nominal with sensitivity to 70% at 40 ± 2 degrees of zero axis. **Figure 2** shows cone vision of typical sensor.

**Temperature range:** *Operating:* -40°F to 167°F (-40°C to 75°C). *Storage:* -67°F to 185°F (-55°C to 85°C).

**Dimensions:** See **Figure 3**.

**Enclosure:** Explosion-proof and watertight, anodized aluminum. *Explosion-proof:* Class 1, Div. 1, Groups C, D. Class II Div. 1, Groups E,F,G. *Watertight:* NEMA 4. *Conduit fitting:* 3/4 inch NPT (Female).

**Shock and vibration:** meets MIL STD 810C vibration.

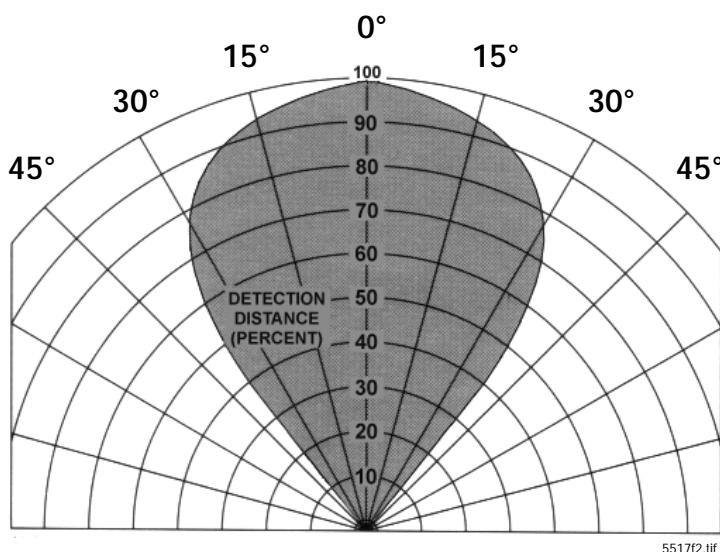

**Figure 2**  
**Cone of Vision of Detector**

100% represents the maximum detection distance for a given fire.

The sensitivity increases as the angle of incidence decreases.

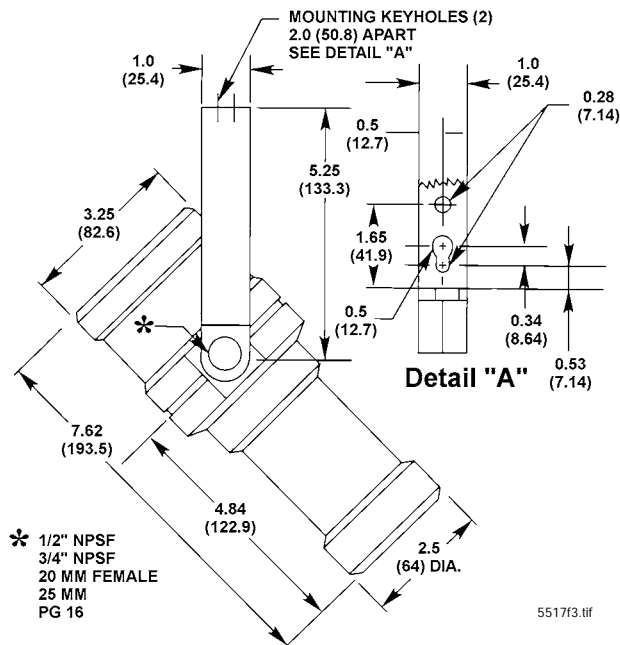

Figure 3  
Dimensions in Inches (mm)

## Maintenance

To assure maximum detector sensitivity, the lens must be kept free of dirt or other contaminating film.

The detector should be tested regularly. If it fails a test, clean the lens and test again. If the detector fails again, it should be removed and replaced. The defective detector should be sent to the factory for repairs.

**NOTE:** Remove power to the detector before cleaning the lens or disconnecting external wiring.

## Checkout Procedure

A checkout of the system using the **oi** feature, a flame, or other flickering IR source should be performed on a regularly scheduled basis to ensure that the system is operating properly. The period between checkouts will depend on the levels of potential hazard involved in the environmental conditions encountered. In general, the more frequent the checkouts, the greater the reliability of the system.

Any extinguishing equipment connected to the system must be disabled when the system is tested to prevent unwanted actuation of this equipment. To test the system, point a test lamp at each unit or activate the remote test feature for five to ten seconds. Alarm response indicates that the viewing window is clean and that all electronic circuitry is operational. Lack of response may indicate reduced sensitivity due to contamination on the viewing window, a damaged sensor, or electronic circuitry problems.

## Installation

The installer should provide a 3/4-inch conduit to the appropriate point where the detector is to be located. This conduit must be grounded. All wiring cables to the detectors must be shielded and the shields must be grounded. The use of conduit seals is recommended.

### **CAUTION!**

**To prevent ignition of a hazardous atmosphere, do not remove the cover while power is applied to the detector.**

1. Provide a shielded wiring cable (16 to 22 AWG recommended) with a minimum of 6 inches service loop at the junction box.

**NOTE:** Be certain that all wiring complies with the local wiring codes. If necessary, consult a qualified official.

2. Connect the external wiring to the detector as illustrated in **Figure 4**.

3. Place the cover on the detector. Be sure the O-ring is in place and that no wires are trapped.

4. To ensure proper coverage of the surveillance area, orient the detector so that the lens faces the center of the area to be protected.

5. Clean the **oi** ring and sensor window with a clean lint-free cloth. Wet with alcohol only.

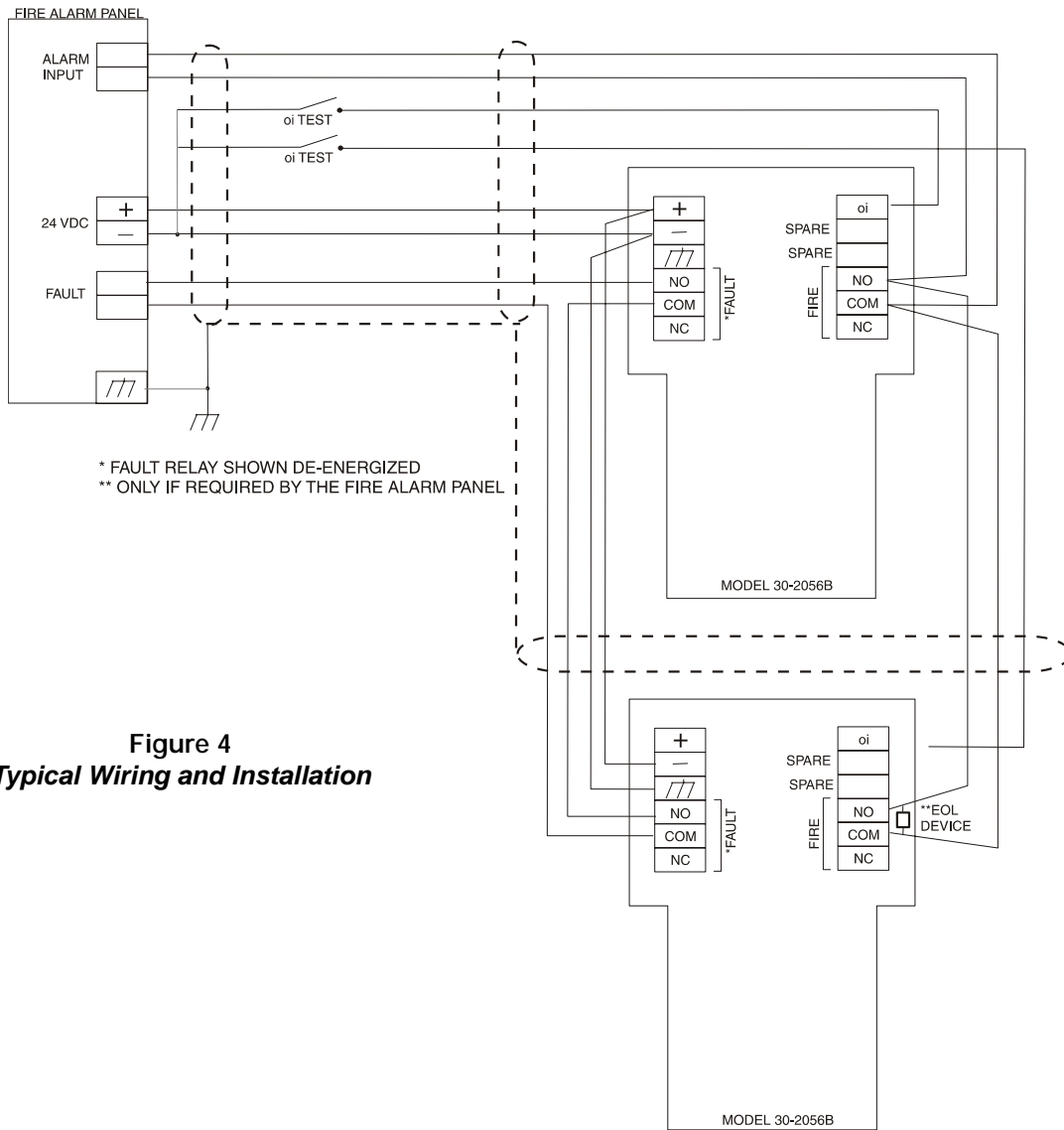

**Figure 4**  
**Typical Wiring and Installation**

5517f4.wmf

Pyrotector is a product of Detector Electronics Corporation. Fire•Lite® Alarms is a registered trademark of Honeywell International Inc. ©2007 by Honeywell International Inc. All rights reserved. Unauthorized use of this document is strictly prohibited.



This document is not intended to be used for installation purposes.  
 We try to keep our product information up-to-date and accurate.  
 We cannot cover all specific applications or anticipate all requirements.  
 All specifications are subject to change without notice.

For more information, contact Fire•Lite Alarms. Phone: (800) 627-3473, FAX: (877) 699-4105.  
[www.firelite.com](http://www.firelite.com)